

APPLICATION OF THE ACR-NEMA DIGITAL DATA INTER-  
CHANGE STANDARD TO THE GRAPHICS ART INDUSTRY.

RANJAN BEDEKAR (\*)

Abstract:

Efforts are underway in the Graphics Arts industry to specify a standard for interchange of digital data between digital, electronic equipment used within the industry (Color Electronic Prepress Systems; Design/Paint Systems; Color Digital Proofing Systems, Electronic Page Layout Systems, etc).

A similar effort began around four years ago in the medical digital imaging field, and culminated successfully with the ACR-NEMA (American College of Radiologists-National Electrical Manufacturers Association) standard of 1985. Although significant differences exist between the two applications, the intent in both applications is to allow transfer of digital images between mixed-vendor equipment. The ACR-NEMA standard provides an excellent template for formulating corresponding standards for the graphics arts industry.

Background:

Digital, medical imaging modalities encompass a variety of equipment, including CT scanners; MR imaging equipment; nuclear cameras; ultrasound systems; and X-Ray film digitizers. Most of these devices produce a digital raster image for viewing upon a color or monochrome monitor. However, the internally-held digital data formats have been incompatible between most of these devices.

The desire for a picture archival and communications system (PACS) standard was first given formal expression at a special PACS conference (\*) Graphics Preparation Systems Division, 3M Co.

erence sponsored by the Society of Photographic and Instrumentation Engineers (SPIE) in 1982 [1]. Prior to this conference, the American Association of Physicists in Medicine (AAPM) had formalized a proposal for a standard magnetic tape exchange format, which was presented at this SPIE conference [2]. This momentum for digital data exchange standards was formalized under a user group (American College of Radiologists) (ACR), and a vendor trade group (National Electrical-Manufacturers Association) (NEMA), in 1983. The ACR-NEMA standards committee published the first official version of the standard in late 1985 ( NEMA publication number 300-1985).[3].

#### The ACR-NEMA standard:

The ACR-NEMA standards effort began by looking at the requirements of radiologists and other physicians. Two requirements were apparent. The first was to have a standard format for transferring images between mixed-vendor equipment. The second was to link images to the main entity in the application, the patient. The ISO OSI ( International Standards Organization, Open System Interconnection) seven-layer template was chosen to define the ACR-NEMA standard.

The ACR-NEMA standard defines layers 1 to layer 7 (physical; data link; network; transport; session; presentation; and application) as defined in the ISO-OSI model [4](Figure 1). However, it simplifies the implementation by assuming that data exchange is between two 'peers' talking 'point to point'. It thus avoids the complexities involved in defining precedence of dialog and of collision handling in a multiple node network (for example, a local area network). In order to implement multiple device networks under ACR-NEMA, a special piece of equipment, called the NIU (network interface unit) converts the ACR-NEMA protocol to the appropriate multiple node network protocol (for example, IEEE 802.4 class of token passing local network protocol implemented over a broadband cable).

## OSI LAYERS

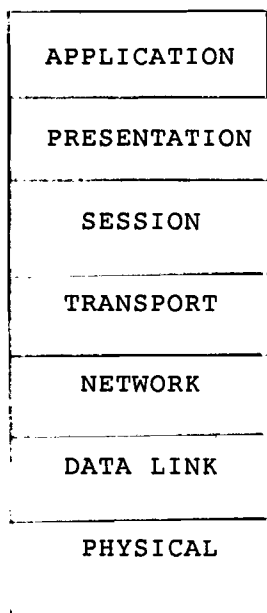

## ACR-NEMA LAYERS

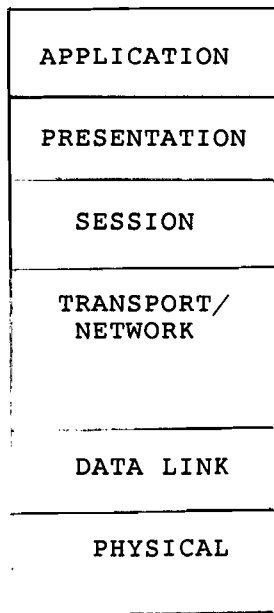

Figure 1: Comparison of ISO-OSI layers and ACR-NEMA layers.

### The ACR-NEMA physical layer (layer 1):

The ACR-NEMA physical layer is defined as a 50-pin connector. This can connect directly to another ACR-NEMA device, or to a network interface unit (NIU). The goal of the specification is to allow a maximum of 8 megabytes/second (at up to 15 meters) data transfer. Such speeds are provided through a 16 bit-parallel, bidirectional data path; and EIA 485 [5] balanced, differential drivers and receivers.

### The ACR-NEMA data link layer (layer 2):

The data link layer works with data entities known as frames. The concept of restricting the protocol as a dialog between just two devices simplified the data link protocol, into just three classes of commands/responses: data and data acknowledge/no acknowledge; status request/response; and a diagnostic echo data command/response. These commands/responses are part of the frame descriptor word, which prefaces the 'packet' created by layer 3. A FCS (Frame Check-Sequence) is the last word in the frame.

### The ACR-NEMA transport/network layer(layers 3/4):

The ACR-NEMA committee decided that the point to-point protocol definition within ACR-NEMA made the delineation between the transport and network layers unnecessary, since there is no routing required within the protocol. The transport/network layer works with data entities called packets. These packets are sent over logical transmission pipes called 'channels'. Multiple channels may be active during an ACR-NEMA session. Any ACR-NEMA device must support a minimum of one channel. The transport/network layer fragments 'messages' from the session layer into blocks of 4096 bytes; it then prefaces the message block with a packet descriptor, and a block sequence number. The protocol is simple, with requests/responses concerned with opening, closing or resetting channels. Flow control is maintained through the Pause/Resume commands.

### The ACR-NEMA session layer (layer 5):

The ACR-NEMA session layer maintains end-to-end data flow through data-flow pipes called 'connections'. An ACR-NEMA device may have multiple data transfers occurring simultaneously. Some of these data transfers may be taking place through an external network, through network interface units (NIU's). It is the job of the session layer to keep track of these connections, and ensure orderly data flow. The session layer uses a 32 byte source, and a 32 byte destination address, when

requesting a connection with a specific destination . These addresses are unique within a specific ACR-NEMA installation. The session layer also uses a connection control word to request connections; disconnect connections; and for data flow control.

The ACR-NEMA presentation and application layers (layers 6,7):

The definition of the presentation and application layers within ACR-NEMA is of major interest to people in Graphics Arts who have an interest in providing digital data exchange standards to allow picture transfer between competing vendors in the industry. The ACR-NEMA standards committee had many similar problems to those faced within the Graphic Arts industry, namely:

Picture dimension; Rows and columns; Picture-Orientation; Pixel size; Pixel interleaving (color pictures); Number of bits per color separation within a pixel; Compression techniques; Region-of-Interest overlays; Picture geometry; Picture-resolution; Picture Rescaling requirements, and the provisions for lookup tables to allow raster display of gray scales or color separations.

The ACR-NEMA application works with structured packages of information called messages. Messages are split into entities called groups. One of the groups is called the command group, and is used to send application layer commands/responses between two ACR-NEMA devices.

The command/response set is made up of four classes:

- a) An originator (application A) in device 1 telling application B in device 2 to send the originator information in the form of one or more messages, via a GET\_REQUEST command,
- b) An originator application in device 1 requesting the destination application to accept information from the originator, via a SEND\_REQUEST command,
- c) An originator application requesting the destination application to locate specific information via a FIND\_REQUEST command,

- d) An originator application requesting the destination application to send information to a third party (application C in device 3, as an example), via the MOVE\_REQUEST command,
- e) An interactive device (for example, a database inquiry/response terminal) sending and receiving unformatted information, with the DIALOG command,
- f) The diagnostic command, ECHO\_REQUEST.

Any group other than the command group, is called a data set. A data set is made up of standard group sets called IMAGE; TEXT; and GRAPHICS. Images, text and graphics in a format beyond the scope of the standard use the PRIVATE class groups. The primary application entity in the medical digital imaging application is a patient. Associated with the patient are a set of images, built as an hierarchy, in the following descending order: study; series; acquisition; image. The highest level of the hierarchy is the patient study. The patient study may be conducted over a long period of time, and patient images may be acquired from more than one medical imaging equipment. The next lower item in the hierarchy is a series. A series is a set of images, acquired over a short period of time, usually from one digital imaging piece of equipment. An acquisition is a single continuous gathering of data, which may contain one or more images.

A patient carries identifying tag group information. Examples of this information are name, sex, and age. A study, session, acquisition or image also carries identifying tag information. Examples of such information are date, time, acquisition modality, equipment manufacturer, and institution.

Eight data groups have been defined under ACR-NEMA. These are:

- a) The identifying information group. This group contains identifying information about the image-set being transferred. Examples of fields within this group are: Dataset type; Manufacturer code; Institution ID; Physician ID; Network and Station ID.
- b) The patient information group. This group

contains all relevant information about the patient. Examples of fields within this group are: Patient name; address; sex; age; birth-date; and insurance plan ID.

c) The acquisition information group. This group contains information about the technique used to acquire the image(s), with fields allocated to allow for the vastly different methods used in acquiring these images.

d) The relationship information group. This group contains information about the relationship of images within a study, series and an acquisition. It contains fields describing the patient orientation; image orientation; and the relationship of a modified image to the original.

e) Image presentation group. This group describes a specific image in terms of dimensions; pixel sizes; and conversion requirements (rescaling or table-lookup).

f) Text group. This group contains a string of ASCII characters. No fonts; text size or text orientation is defined under ACR-NEMA.

g) Overlay group. This group defines image overlays (for example, a region of interest) of original images.

h) Pixel group. This group contains pixel image data, as defined under earlier groups.

The identification of an image within ACR-NEMA:

An image, within ACR-NEMA, can be of three types:

Original, where pixel values have not been modified, Modified, where pixel values have been transformed, and Composite, where two or more images have been combined into one image.

All images have tags (identifiers) associated with them. These tags identify the image uniquely, and also describe the image.

Regions of interest, reference marks and annotation text is sent through 'overlay planes', which are associated with a specific image. Images may be in monochrome; pseudocolor, or RGB (Red/Green/Blue) true-color. The number of bits defining the intensity (gray scale or color) per pixel can be variable.

Perhaps the most remarkable thing about the ACR-NEMA standard is its flexibility within a framework tailored specifically for the user's needs. Whenever special needs are encountered, the 'shadow' groups (for example, the PRIVATE IMAGE) are available for customized use. We at 3M, have scanned in a color transparency upon a color scanner; saved it on a minicomputer disk; and used 3M-designed NIU's (network interface units) [6], which use the ACR-NEMA protocol, to send the picture, over a broadband local area network to another minicomputer on the local network. Figures 2 and 3 show a 3M-like, broadband cable-based implementation of ACR-NEMA within a hospital. The NIE's (Network Interface Equipment) in the figures are identical to the NIU's (Network Interface Unit's) described earlier.

Comparison with the Graphic Arts digital images applications:

Application layer similarities:

If we substitute the concept of a 'patient' in the ACR-NEMA application, with the concept of a 'job' within the Graphic Arts application, the hierarchical similarities between the two applications are striking.

The ACR-NEMA application has an originator (physician/radiologist) who requests the images; an institution (hospital/health center); and relevant patient information (patient name; birthdate; sex; age; address; insurance plan; and patient computer ID). A job in our application, has an originator (customer); we also need information on the originator (name; address; contact person, etc.) an institution where the job is completed (trade shop/printer); a start time, and a schedule; and cost estimate information and payment information.

A variety of images are associated with a patient in the ACR-NEMA application. Many of the images need modification before and during viewing (for example, averaging and subtraction of images is common for an angiograph study).

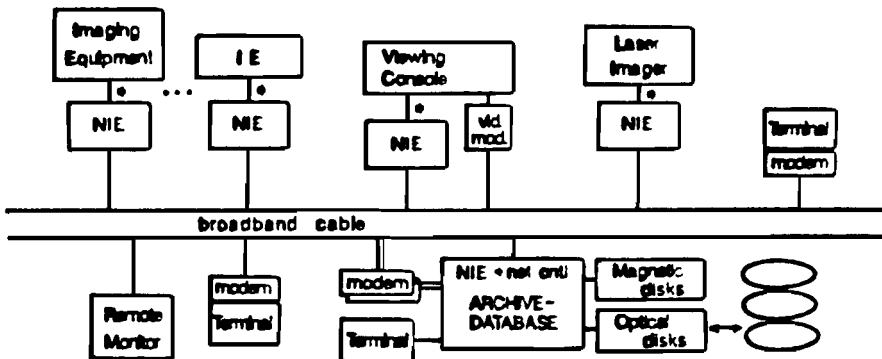

• ACR-NEMA interface to Network Interface Element (NIE)

FIGURE 2. Schematic of diagnostic equipment connected to a network

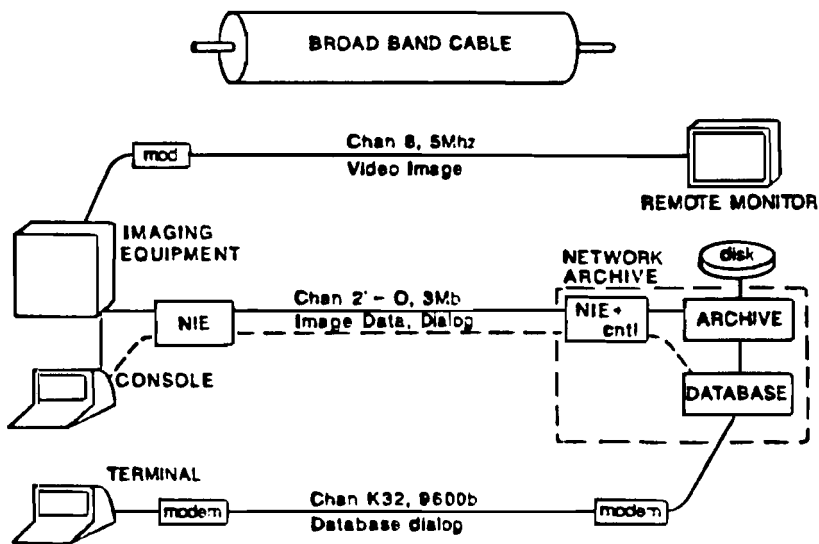

FIGURE 3. Illustration of multiple networks on a broad band cable

Compression (zooming) of images is also a common requirement. Composite images may be required during viewing of magnetic resonance images.

The Graphic Art application also works with a variety of images (four-color pictures; scanned-art; page layout parameters; and text). These images may be modified (for example, a color picture after a retouch operation); and composite images are usually created (for example, after a page layout). The original images may be upon film, and need to be converted to digital format, or may be available in digital format on an archival device. The pages, after composition, may be archived. Image and job databases may now be queried as in the ACR-NEMA application (for example, through the DIALOG command under ACR-NEMA).

The major difference between the applications is what happens after the image viewing and composition. The Graphic Arts application requires that the composed page be output to a hard-copy device for proofing, and finally for printing. Under ACR-NEMA, the viewing of original, modified or composite images, (and perhaps their archival) is an end in itself.

#### Differences:

The major differences between computer-generated Graphic Arts digital images (Color Electronic Pre-press Systems; Design stations; Digital Color Proofers, etc.) and medical digital images are as follows:

a) Picture size:

ACR-NEMA image transfer is generally for raster, soft-copy viewing images, and a typical dimension is 512 x 512 x 8 bits (250 kilobytes). Graphic Art digital images are high resolution, four color images, and may be as large as 100 megabytes. Image compression techniques are not addressed under ACR-NEMA.

b) Content (Color Planes):

Color under ACR-NEMA, is sent as separate planes. Pixel and line interleaving is not defined. Only additive colors (Red/Green/Blue) are supported within the standard.

- c) Content (Orientation):  
Picture orientation is always left to right, top to bottom. Other orientations are not supported.
- d) Content (Halftones):  
ACR-NEMA only addresses the requirements of typical output devices in the medical application, namely: viewing displays, and archival devices. The requirement to convert a stream of bits into halftone information for hardcopy output devices, a critical element in the Graphics Arts industry, is not addressed under ACR-NEMA.
- e) Content (Geometric/Scanned Art):  
Geometric masks (for example, rectangles, circles, ellipses, polylines) used in Graphic Arts electronic page layout equipment, are not addressed under ACR-NEMA. The ANSI GKS (Graphic Kernel-System) and CGI (Computer Graphics Interface) standards (currently under ANSI X3.H3), address these issues more appropriately.
- f) Picture transmission requirements:  
Although the ACR-NEMA concept of a point-to-point connection is simple and elegant, a special network interface unit (NIU) is required for every separate class of network. Long-haul picture transmission is an important element within the Graphic Arts industry, and the peculiarities of this type of transmission medium (possibility of high error rates; breaks in the physical connection, etc.) need to be addressed through a special network interface unit.

### Conclusions:

Any comprehensive digital data interchange standard within the Graphic Arts industry must address all the techniques which may be used for exchange of color picture information between different electronic vendor equipment. These techniques include exchange of picture information through removable media (for example, magnetic tape); exchange of picture information through direct hardware connection between equipment made by two different vendors; exchange of picture information between mixed-vendor equipment attached to a local area network; and picture information transmission between equipment made by two different vendors, over a long-haul network (for example, a 56 kilo bit/ second AT&T T1 link).

To address these differing needs for picture transmission, a well-known and well-accepted, generalized template for data exchange must be incorporated within the standard. This probably means that the ISO OSI model, complex though it is, must be part of the standard. ACR-NEMA has already defined an ISO OSI-based standard, which addresses an application bearing many similarities with the Graphic Arts application. It then, would be very worthwhile for people involved with the Graphic Arts digital data exchange standard to examine the ACR-NEMA standard to see how much of it could be fruitfully used within this new effort.

#### References:

1. Society of Photographic and Instrumentation Engineers; Proceedings of the SPIE, Vol 318, 1982.
2. Maguire, Baxter, Hitchner "American Association of Physicists in Medicine standard magnetic tape format for digital data exchange" *ibid.*, P 284.
3. National Electrical Manufacturers Association, 2101, L Street NW., Suite 300, Washington, D.C. 20037; ACR-NEMA standards publication "Digital Imaging and Communications" , Publication number 300, 1985.
4. Information Processing Systems, Open System-Interconnection-Basic Reference Model ( ISO OSI); International Standards Organization. ISO 7498, 1983.
5. Electronic Industries Association, standard EIA 485 "Standard for electrical characteristics of generators and receivers for use in balanced digital multipoint systems"
6. Nelson, Rennolet (3M) " Implementing the ACR-NEMA protocol on a network", SPIE conference, 1985.